



TEE-HANDLE BRASS BALL VALVE: NPT

- **Sizes Range: 3/8" - 1"**
- **Quarter-Turn Operation**
- **Threads conform to ANSI B1.20.1**

- **Blowout proof stem**
- **MSS-SP-110**



ANSI
Z21.15 1/2 PSIG

Gas Ball Valves are constructed of heavy duty forged brass. They are designed for residential, commercial, and industrial use in low pressure gas applications. Valves listed are suitable for use with natural, manufactured, mixed and LP gases and with LP gas - air mixtures.

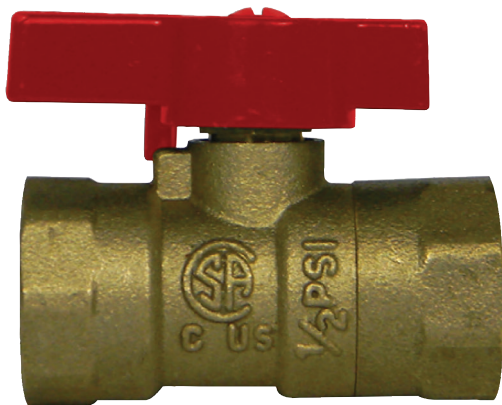

DIMENSIONS

3/8"	(L) 1.81"	(H) 1.22"	(D) .39"
1/2"	(L) 2.17"	(H) 1.22"	(D) .39"
3/4"	(L) 2.44"	(H) 1.38"	(D) .59"
1"	(L) 2.87"	(H) 1.66"	(D) .79"

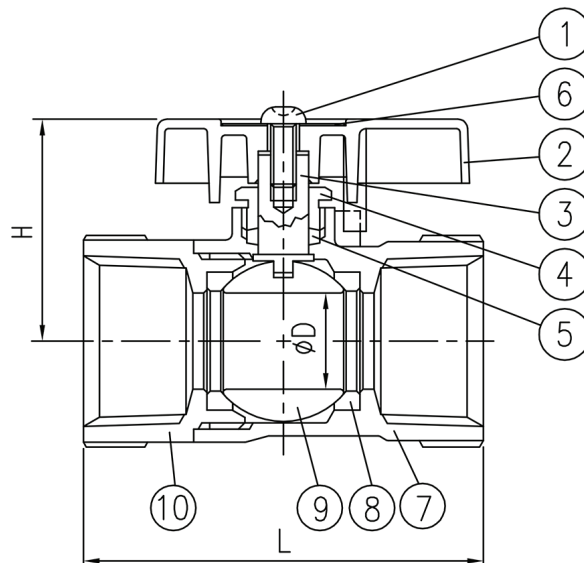
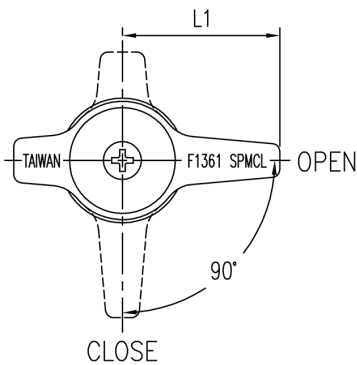

MATERIALS

1. Steel Screw
2. Zinc Alloy Handle
3. Brass Stem
4. Brass Stem Gland Screw
5. PTFE Teflon Gland Packing
6. Name Plate
7. Forged Brass Body
8. PTFE Teflon Ball Disc
9. Forged Brass Ball Disc
10. Forged Brass End Plug

V1117